

Notice for TAIYO YUDEN products

Please read this notice before using the TAIYO YUDEN products.



REMINDERS

- Product information in this catalog is as of October 2008. All of the contents specified herein are subject to change without notice due to technical improvements, etc. Therefore, please check for the latest information carefully before practical application or usage of the Products.

Please note that Taiyo Yuden Co., Ltd. shall not be responsible for any defects in products or equipment incorporating such products, which are caused under the conditions other than those specified in this catalog or individual specification.

- Please contact Taiyo Yuden Co., Ltd. for further details of product specifications as the individual specification is available.
- Please conduct validation and verification of products in actual condition of mounting and operating environment before commercial shipment of the equipment.
- All electronic components or functional modules listed in this catalog are developed, designed and intended for use in general electronics equipment.(for AV, office automation, household, office supply, information service, telecommunications, (such as mobile phone or PC) etc.). Before incorporating the components or devices into any equipment in the field such as transportation,(automotive control, train control, ship control), transportation signal, disaster prevention, medical, public information network (telephone exchange, base station) etc. which may have direct influence to harm or injure a human body, please contact Taiyo Yuden Co., Ltd. for more detail in advance.

Do not incorporate the products into any equipment in fields such as aerospace, aviation, nuclear control, submarine system, military, etc. where higher safety and reliability are especially required.

In addition, even electronic components or functional modules that are used for the general electronic equipment, if the equipment or the electric circuit require high safety or reliability function or performances, a sufficient reliability evaluation check for safety shall be performed before commercial shipment and moreover, due consideration to install a protective circuit is strongly recommended at customer's design stage.

- The contents of this catalog are applicable to the products which are purchased from our sales offices or distributors (so called "TAIYO YUDEN' s official sales channel").
It is only applicable to the products purchased from any of TAIYO YUDEN' s official sales channel.
- Please note that Taiyo Yuden Co., Ltd. shall have no responsibility for any controversies or disputes that may occur in connection with a third party's intellectual property rights and other related rights arising from your usage of products in this catalog. Taiyo Yuden Co., Ltd. grants no license for such rights.
- Caution for export
Certain items in this catalog may require specific procedures for export according to "Foreign Exchange and Foreign Trade Control Law" of Japan, "U.S. Export Administration Regulations," and other applicable regulations. Should you have any question or inquiry on this matter, please contact our sales staff.
Should you have any question or inquiry on this matter, please contact our sales staff.

巻線データラインフィルタ

WOUND TORROIDS AND BEADS



フロー/WAVE

OPERATING TEMP.	-25~+105°C (製品自己発熱含む) (Including self-generated heat)
-----------------	--

特長 FEATURES

- ・損失分の大きなフェライト材料を使用
- ・ノーマルモード用としてインピーダンスが大きい
- ・テーピング供給により自動挿入対応 (05RD)
- ・大電流対応 (06BT)
- ・ Use of high loss ferrite materials for excellent high frequency noise absorption.
- ・ High impedance for normal mode applications.
- ・ 05 RD type available in taping for automatic insertion.
- ・ 06 BT type is designed for high current applications (3 A).

用途 APPLICATIONS

- ・各種デジタル機器におけるデータラインの高周波ノイズ吸収
- ・ Absorption of high frequency noise from digital equipment data lines.

形名表記法 ORDERING CODE

■FL-R / RD Type

1 形式 FL 巻線形データラインフィルタ	3 形状 R△ リングコア、単線リード直出し RD リングコア、ケース使用ピンタイプ △=スペース	4 公称インダクタンス (μH) 例 R=小数点 IR0 1.0 200 20.0	6 包装 △ 単品 T リールテーピング Z つづら折りテーピング — 個別仕様 △=スペース
2 コアの長辺寸法 (mm) 05 4.8		5 インダクタンス許容差 (%) A 公称値以上 E 特殊許容差	7 当社管理記号 △ 標準品 07 個別仕様連番 △=スペース

F L 0 5 R D 2 0 0 A T ○

1 Type FL Wound torroids and beads	3 Shape R△ Ring core, with single wire lead RD Ring core, with case, pin type △=Blank space	4 Nominal inductance (μH) Example ※R=decimal point IR0 1.0 200 20.0	6 Packaging △ Bulk T Tape & Reel Z Ammo — Special code △=Blank space
2 Dimensions of core (mm) 05 4.8		5 Inductance tolerance (%) A Higher than normal value E Special tolerance	7 Internal code △ Standard product 07 Product classification code △=Blank space

■FL-BT Type

1 形式 FL 巻線データラインフィルタ	3 形状 BT 円柱、多孔コア	4 試作番号 04	5 当社管理記号 △ 標準品 △=スペース
-------------------------------------	--------------------------------	------------------------	---

2 コアの外径寸法 (mm) 06 6.0

F L 0 6 B T 0 4 ○

1 Type FL Wound torroids and beads	3 Shape BT Cylinder, porous core	4 Product classification code 04	5 Internal code △ Standard product △=Blank space
2 Dimensions of core (dia.) (mm) 06 6.0			

外形寸法 EXTERNAL DIMENSIONS

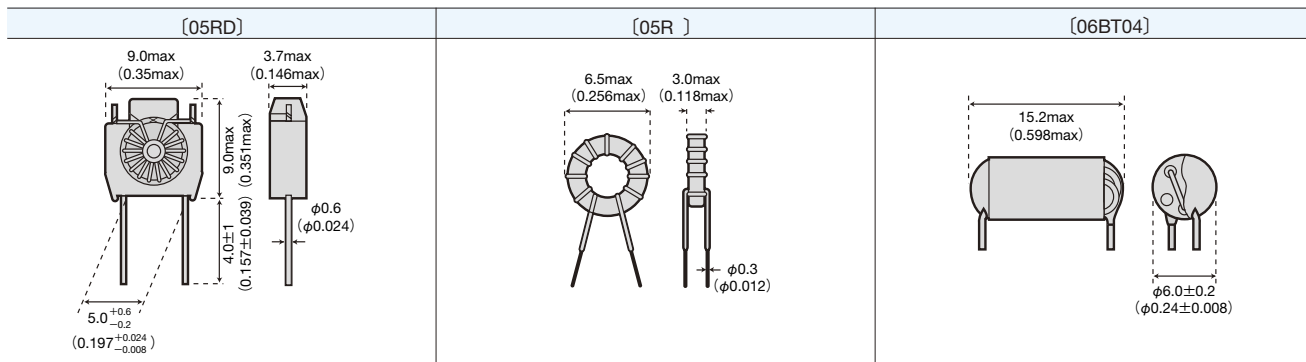

Unit : mm (inch)

インピーダンス周波数特性 IMPEDANCE-FREQUENCY CHARACTERISTICS

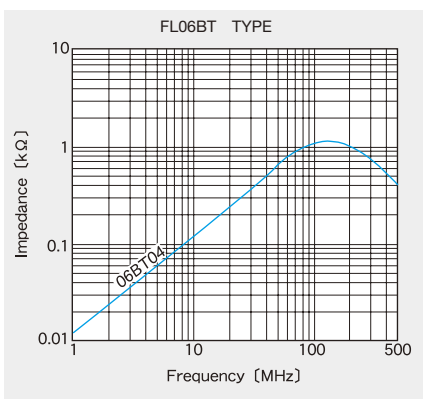
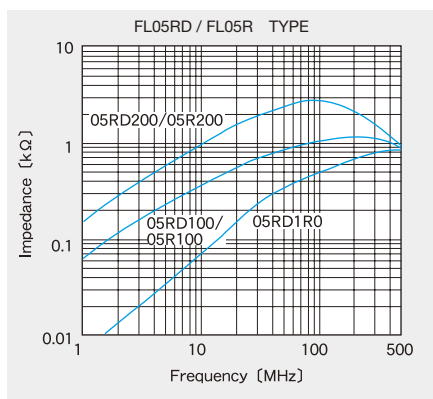

Measured by HP4291A

その他の特性につきましては、ご要望に応じて検討、対応致します。
 Please contact TAIYO YUDEN for further information in regard to other characteristics.

アイテム一覧 PART NUMBERS

形名 Ordering code	EHS (Environmental Hazardous Substances)	インダクタンス Inductance [μH]	インピーダンス Impedance [Ω] (typical)	直流抵抗 DC Resistance [Ω] (max)	定格電流 Rated current [A] (max)
FL05RD1R0E□	RoHS	1.0 ^{+1.0} / _{-0.5}	800 (at 400MHz)	0.08	0.5
FL05R 100A	RoHS	10min	900 (at 200MHz)	0.05	1.5
FL05RD100A□	RoHS				
FL05R 200A-07	RoHS	20min	2000 (at 100MHz)	0.08	
FL05RD200A□	RoHS				
FL06BT04	RoHS	—	1000 (at 150MHz)	0.05	3.0

□は包装記号が入ります。(T: リールテーピング、Z: つづら折りテーピング、スペース: 単品)
 □ Please specify the packaging code (T: Tape & reel, Z: ammo, Blank space: bulk)

セレクションガイド
Selection Guide

アイテム一覧
Part Numbers

特性図
Electrical Characteristics

梱包
Packaging

信頼性
Reliability Data

使用上の注意
Precautions

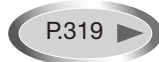

etc

①最小受注単位数 Minimum Quantity

Type	最小受注単位数 (pcs.) Minimum Quantity		
	袋づめ	リールテーピング	つづり折りテーピング
	Bulk	Tape and Reel	Ammo
FL05R	500	—	—
FL05RD	400	2000	1500
FL06BT	250	—	—

②テーピング寸法 Taping dimensions
FL05RD

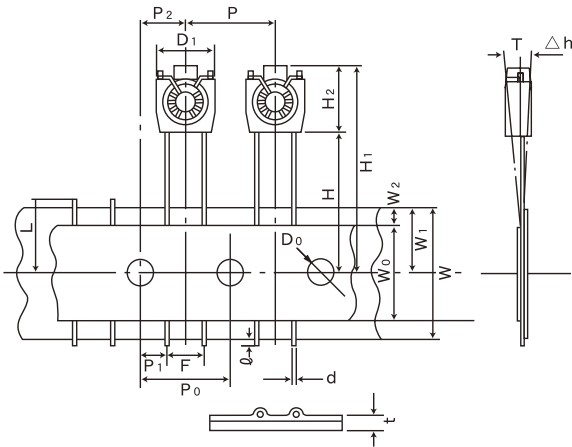

③リール寸法 Reel size
FL05RD

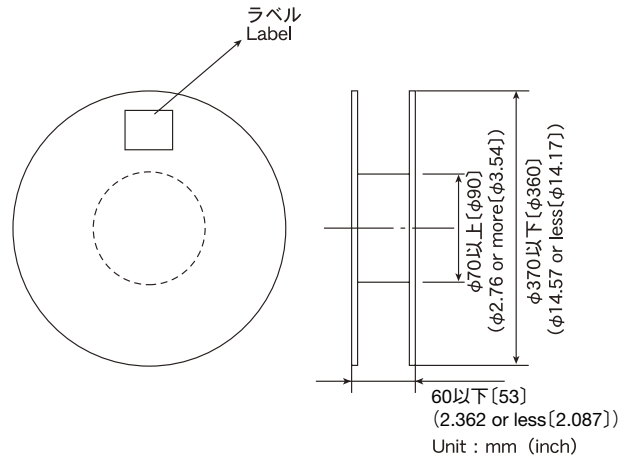

寸法表示の〔 〕は実寸法。
Dimensions in parenthesis are measured value.

Type	記号 Symbol	寸法 [mm (inch)] Dimension
FL05RD	D ₁	9.0max (0.354max)
	H ₂	9.0max (0.354max)
	T	3.7max (0.146max)
	H ₁	31.0max (1.22max)
	H	18.0±1.0 (0.709±0.039)
	P	12.7±1.0 (0.500±0.039)
	P ₀	12.7±0.3 (0.500±0.012) ^{※1}
	P ₁	3.85±0.8 (0.152±0.031)
	P ₂	6.35±1.3 (0.250±0.051)
	W ₁	9.0 ^{+0.75} _{-0.5} (0.354 ^{+0.030} _{-0.020})
	F	5.0 ^{+0.6} _{-0.2} (0.197 ^{+0.024} _{-0.008})
	d	φ0.6 (φ0.024)
	Δh	0±2.0 (0±0.079)
	W	18.0 ^{+1.0} _{-0.5} (0.709 ^{+0.024} _{-0.008})
	W ₀	12.5min (0.492min)
	W ₂	3.0min (0.118min) ^{※2}
	ℓ	0max (0max)
D ₀	4.0±0.3 (0.157±0.012)	
L	11.0max (0.433max)	
t	0.7±0.2 (0.028±0.008)	

※1.20ピッチにつき累積誤差±2mm以内
 ※2.貼付テープは台紙よりはみ出さないこと
 ※1.Accumulated error for 20 pitches shall be within ±2mm.
 ※2.Pasting tape shall not exceed paste board.

Item	Specified Value						Test Method and Remarks
	FA02 Type	CAL45 Type	LHL □□□	FBA/FBR	FL05 □ Type	FL06BT Type	
1. Operating temperature Range	-25~+105°C			-25~+85°C	-25~+105°C		FA・CA・FL : Including self-generated heat LHL□□□ : Including self-generated heat
2. Storage temperature Range	-40~+85°C						
3. Rated current	Within the specified tolerance						FA・CA : The maximum DC value having inductance within 10% and temperature increase within 20°C by the application of DC bias. LHL□□□ : The maximum DC value having inductance decrease within 10% (LHLC08, LHLC10 : within 30%) and temperature increase within the following specified temperature by the application of DC bias. Reference temperature : 25°C (LHL08, LHL10, LHL13) : 30°C (LHL16, LHLP□□) : 40°C (LHLC08, LHLC10) FB : No disconnection or appearance abnormality by continuous current application for 30 min. Change after the application shall be within ±20% of the initial value. This is not guaranteed for electrical characteristics during current application. FL : The maximum DC value having temperature rise within specified value.
4. Impedance				Within the specified tolerance		Refer to individual specification	FB : Measuring equipment : Impedance analyzer (HP4191A) or its equivalent Measuring frequency : Specified frequency FL06BT : Measuring equipment : 4291A (HP) or its equivalent Measuring frequency : Specified frequency
5. Inductance	Within the specified tolerance				Within the specified tolerance		FA・CA : Measuring equipment : LCR meter (HP4285A + HP42851A or its equivalent) Measuring frequency : Specified frequency LHL□□□ : Measuring equipment : LCR meter (HP4285A + HP42851A or its equivalent) LCR meter (HP4262A) or its equivalent (at 1KHz) Measuring frequency : Specified frequency FL05R□ : Measuring equipment : HP4262A or its equivalent. Measuring frequency : 1kHz

Item	Specified Value						Test Method and Remarks												
	FA02 Type	CAL45 Type	LHL□□□	FBA/FBR	FL05□ Type	FL06BT Type													
6.Q	Within the specified tolerance						FA・CA : Measuring equipment : LCR meter (HP4285A+HP42851A or its equivalent) Measuring frequency : Specified frequency LHL□□□ (except LHLP) : Measuring equipment : LCR meter (HP4285A+HP42851A or its equivalent) LCR meter (HP4262A) or its equivalent (at 1kHz) Measuring frequency : Specified frequency												
7.DC Resistance	Within the specified tolerance						FA・CA : Measuring equipment : low ohmmeter (A&D AD5812 or its equivalent) LHL□□□・FB・FL : Measuring equipment : DC ohmmeter												
8.Self resonance frequency	Within the specified tolerance						FA・CA : Measuring equipment : Network analyzer (Anritsu MS620J or its equivalent) LHL□□□ (except LHLP) : Measuring equipment : (HP4191A, 4192A) its equivalent												
9.Temperature characteristic	△L/L : Within ±5%		△L/L : Within ±7% (except LHLP16 : Within ±20%)				FA・CA : Change of maximum inductance deviation in step 1to5 <table border="1" style="margin-left: 20px;"> <thead> <tr> <th>step</th> <th>Temperature (°C)</th> </tr> </thead> <tbody> <tr> <td>1</td> <td>20</td> </tr> <tr> <td>2</td> <td>-25 (Minimum operating temperature)</td> </tr> <tr> <td>3</td> <td>20 (Standard temperature)</td> </tr> <tr> <td>4</td> <td>+85 (Maximum operating temperature)</td> </tr> <tr> <td>5</td> <td>20</td> </tr> </tbody> </table> LHL□□□ Change of maximum inductance deviation in step 1to5 Temperature at step 1 : 20°C Temperature at step 2 : Minimum operating temperature Temperature at step 3 : 20°C (Standard temperature) Temperature at step 4 : Maximum operating temperature Temperature at step 5 : 20°C	step	Temperature (°C)	1	20	2	-25 (Minimum operating temperature)	3	20 (Standard temperature)	4	+85 (Maximum operating temperature)	5	20
step	Temperature (°C)																		
1	20																		
2	-25 (Minimum operating temperature)																		
3	20 (Standard temperature)																		
4	+85 (Maximum operating temperature)																		
5	20																		

Item	Specified Value						Test Method and Remarks																					
	FA02 Type	CAL45 Type	LHL□□□	FBA/FBR	FL05□ Type	FL06BT Type																						
10. Terminal strength : tensile force	No abnormality such as cut lead, or looseness.			No abnormality such as cut lead, or looseness.	No abnormality such as cut lead, or looseness.		FA・CA : Apply the stated tensile force progressively in the direction to draw terminal. <table border="1"> <tr> <th>force (N)</th> <th>duration (S)</th> </tr> <tr> <td>25</td> <td>5</td> </tr> </table> LHL□□□ : Apply the stated tensile force progressively in the direction to draw terminal. <table border="1"> <tr> <th>Nominal wire diameter tensile ϕ d (mm)</th> <th>force (N)</th> <th>duration(S)</th> </tr> <tr> <td>0.3 < ϕ d ≤ 0.5</td> <td>5</td> <td rowspan="3">30 ± 5</td> </tr> <tr> <td>0.5 < ϕ d ≤ 0.8</td> <td>10</td> </tr> <tr> <td>0.8 < ϕ d ≤ 1.2</td> <td>25</td> </tr> </table> FBA/FBR : A bead shall be fixed and static loaded 20 ± 1N (2.0 ± 0.1 kgf) in axial direction of lead wire in 10 ± 1 seconds. FL05R□ : Fix the component in the direction to draw terminal, and gradually apply the tensile force of 4.9 N.	force (N)	duration (S)	25	5	Nominal wire diameter tensile ϕ d (mm)	force (N)	duration(S)	0.3 < ϕ d ≤ 0.5	5	30 ± 5	0.5 < ϕ d ≤ 0.8	10	0.8 < ϕ d ≤ 1.2	25							
force (N)	duration (S)																											
25	5																											
Nominal wire diameter tensile ϕ d (mm)	force (N)	duration(S)																										
0.3 < ϕ d ≤ 0.5	5	30 ± 5																										
0.5 < ϕ d ≤ 0.8	10																											
0.8 < ϕ d ≤ 1.2	25																											
11. Over current			There shall be no scorch or short of wire. LHLC08, LHLC10: There shall be no firing.				LHL□□□ : Measuring current : Rated current × 2 Duration : 5min. Number of measuring : one time																					
12. Terminal strength : bending	No abnormality such as cut lead, or looseness.						FA・CA : Suspend a mass at the end the terminal, incline the body though angel of 90 and return it to initial position. This operation is done over a period of 2-3 sec. Then second bend in the opposite direction shall be made. Number of bends : Two times. <table border="1"> <tr> <th>Nominal wire diameter tensile ϕ d (mm)</th> <th>Bending force (N)</th> <th>Mass reference weight (kg)</th> </tr> <tr> <td>0.3 < ϕ d ≤ 0.5</td> <td>2.5</td> <td>0.25</td> </tr> <tr> <td>0.5 < ϕ d ≤ 0.8</td> <td>5</td> <td>0.50</td> </tr> </table> LH・FB : Suspend a mass at the end the terminal, incline the body though angel of 90 and return it to initial position. This operation is done over a period of 2-3 sec. Then second bend in the opposite direction shall be made. Number of bends : Two times. <table border="1"> <tr> <th>Nominal wire diameter tensile ϕ d (mm)</th> <th>Bending force (N)</th> <th>Mass reference weight (kg)</th> </tr> <tr> <td>0.3 < ϕ d ≤ 0.5</td> <td>2.5</td> <td>0.25</td> </tr> <tr> <td>0.5 < ϕ d ≤ 0.8</td> <td>5</td> <td>0.5</td> </tr> <tr> <td>0.8 < ϕ d ≤ 1.2</td> <td>10</td> <td>1.0</td> </tr> </table>	Nominal wire diameter tensile ϕ d (mm)	Bending force (N)	Mass reference weight (kg)	0.3 < ϕ d ≤ 0.5	2.5	0.25	0.5 < ϕ d ≤ 0.8	5	0.50	Nominal wire diameter tensile ϕ d (mm)	Bending force (N)	Mass reference weight (kg)	0.3 < ϕ d ≤ 0.5	2.5	0.25	0.5 < ϕ d ≤ 0.8	5	0.5	0.8 < ϕ d ≤ 1.2	10	1.0
Nominal wire diameter tensile ϕ d (mm)	Bending force (N)	Mass reference weight (kg)																										
0.3 < ϕ d ≤ 0.5	2.5	0.25																										
0.5 < ϕ d ≤ 0.8	5	0.50																										
Nominal wire diameter tensile ϕ d (mm)	Bending force (N)	Mass reference weight (kg)																										
0.3 < ϕ d ≤ 0.5	2.5	0.25																										
0.5 < ϕ d ≤ 0.8	5	0.5																										
0.8 < ϕ d ≤ 1.2	10	1.0																										
13. Insulation resistance : between the terminals and body			100M Ω min.				LHL□□□ : Applied voltage : 500 VDC Duration : 60 sec.																					
14. Insulation resistance : between terminals and core				1M Ω min. (Other than material code MA)			FBA・FBR : Applied voltage : 100 VDC Duration : 60 ± 5 sec.																					
15. Withstanding : between the terminals and body			No abnormality such as insulation damage				LHL□□□ : According to JIS C5102. 7. 1. 3 (C) Metal global method Applied voltage : 500 VDC Duration : 60 sec.																					

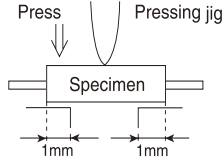
Item	Specified Value						Test Method and Remarks
	FA02 Type	CAL45 Type	LHL□□□	FBA/FBR	FL05□ Type	FL06BT Type	
16.DC bias characteristic	△L/L : Within -10%						FA·CA : Measure inductance with application of rated current using LCR meter to compare it with the initial value.
17.Body strength	No abnormality as damage.			No abnormality such as cracks on body.			FA02 : Applied force : 30N Duration : 10 sec. Speed : Shall attain to specified force in 2 sec. CAL45 : Applied force : 50N Duration : 10 sec. Speed : Shall attain to specified force in 2 sec. FBA : Applied force : 50±3N Duration : 30±1 sec. 
18.Resistance to vibration	△L/L : Within±5% Q : 30min.	△L/L : Within±5%	Appearance : No abnormality △L/L : Within±5% Q change : Within±30% (LHLP : only △L/L)	Appearance : No abnormality Impedance change : Within±20%			FA·CA : Directions : 2 hrs each in X, Y and Z directions total : 6hrs. Frequency range : 10 to 55 to 10Hz(1min.) Amplitude : 1.5mm Mounting method : Soldering onto printed board. Recovery : At least 1hr of recovery under the standard condition after the test, followed by the measurement within 2hrs. LHL□□□·FB : Directions : 2 hrs each in X, Y and Z directions total : 6hrs. Frequency range : 10 to 55 to 10Hz(1min.) Amplitude : 1.5mm (But don't exceed acceleration 196m/s (two power) Mounting method : Soldering onto printed board.

Item	Specified Value						Test Method and Remarks
	FA02 Type	CAL45 Type	LHL□□□	FBA/FBR	FL05□ Type	FL06BT Type	
19. Resistance to shock	No significant abnormality in appearance						FA・CA : Drop test Impact material : concrete or vinyl tile Height : 1m Total number of drops : 10 times
20. Solderability	At least 75% of terminal electrode is covered by new solder.	At least 75% of lead circumference is covered by new solder.	At least 90% of lead circumference is covered by new solder.	At least 75% of lead circumference is covered by new solder.			FA・CA : Solder temperature : 230±5°C Duration : 2±0.5 sec. LHL□□□ : Solder temperature : 235±5°C Duration : 2±0.5 sec. Immersion depth : Up to 1.5mm from bottom of case. FB : Solder temperature : 230±5°C Duration : 3±1 sec. Immersion depth : Up to 1.5mm from terminal root. FL05R□ : Solder temperature : 230±5°C Duration : 2±0.5 sec. Immersion depth : Up to 2~2.5mm from terminal root. FL06BT : Solder temperature : 230±5°C Duration : 3±1 sec. Immersion depth : Up to 0.5~1.0mm from terminal root.

Item	Specified Value						Test Method and Remarks
	FA02 Type	CAL45 Type	LHL□□□	FBA/FBR	FL05□ Type	FL06BT Type	
21. Resisistance to soldering heat	No significant abnormality in appearance		No significant abnormality in appearance Inductance change : Within ±5% Q change : Within ±30% (LHLP : only △L/L)	No significant abnormality in appearance Impedance change : Within ±20%	Refer to individual specification	No significant abnormality in appearance Impedance change : Within ±20%	<p>FA・CA :</p> <p>Solder temperature : 260±5°C (CP02・LA02) 270±5°C (LA03・LA04・LA45)</p> <p>Duration : 5±0.5 sec. One time</p> <p>Immersed conditions : Inserted into substrate with t = 1.6mm</p> <p>Recovery : At least 1hr of recovery under the standard condition after the test, followed by the measurement within 2hrs.</p> <p>LHL□□□ :</p> <p>Solder bath method Solder temperature : 260±5°C Duration : 10±1 sec. : Up to 1.5mm from bottom of case.</p> <p>Manual soldering Solder temperature : 350±10°C (At the tip of soldering iron) Duration : 5±1 sec. : Up to 1.5mm from bottom of case.</p> <p>Caution : No excessive pressing shall be applied to terminald</p> <p>Recovery : 4 to 24hrs of recovery under the standard condition after the tset.</p> <p>FB :</p> <p>Solder bath method Condition 1 Solder temperature : 260±5°C Duration : 10±1 sec. Immersion depth : Up to 1.5mm from terminal root.</p> <p>Condition 2 Solder temperature : 350±5°C Duration : 3±1 sec. Immersion depth : Up to 1.5mm from terminal root. Recovery : 3hrs of recovery under the standard condition after the test.</p> <p>FL :</p> <p>Solder condition : 260±5°C 10±1 sec. Immersion depth : Up to 0.5 to 1.0mm from terminal root. Recovery : 3hrs of recovery under the standard condition after the test.</p>

Item	Specified Value						Test Method and Remarks																																													
	FA02 Type	CAL45 Type	LHL□□□	FBA/FBR	FL05□ Type	FL06BT Type																																														
22.Resistance to solvent	Please avoid the ultrasonic cleaning of this product.			No significant abnormality in appearance Impedance change : Within±20%			FB : Solvent temperature : 20~25°C Duration : 30±5 sec. Solvent type : Acetone, trichloroethylene Recovery : 3hrs of recovery under the standard condition after the test.																																													
23.Thermal shock	△L/L : Within±10% Q : 30min.	△L/L : Within±10%	Appearance : No abnormality Inductance change : Within±10% Q change : Within±30% (LHLP : only △L/L)	Appearance : No abnormality Impedance change : Within±20%	Refer to individual specification	Appearance : No abnormality Impedance change : Within±20%	FA・CA : Conditions for 1cycle <table border="1"> <thead> <tr> <th>Step</th> <th>Temperature (°C)</th> <th>Duration (min)</th> </tr> </thead> <tbody> <tr> <td>1</td> <td>-25⁺⁰₋₃</td> <td>30±3</td> </tr> <tr> <td>2</td> <td>Room temperature</td> <td>Within 3</td> </tr> <tr> <td>3</td> <td>+85⁺²₋₀</td> <td>30±3</td> </tr> <tr> <td>4</td> <td>Room temperature</td> <td>Within 3</td> </tr> </tbody> </table> Number of cycles : 5 cycles Recovery : At least 1hr of recovery under the standard condition after the removal from test chamber, followed by the measurement within 2hrs. LHL□□□・FB : According to JIS C0025 Conditions for 1 cycle <table border="1"> <thead> <tr> <th>Step</th> <th>Temperature (°C)</th> <th>Duration (min)</th> </tr> </thead> <tbody> <tr> <td>1</td> <td>Minimum operating temperature⁺⁰₋₃</td> <td>30±3</td> </tr> <tr> <td>2</td> <td>Room temperature</td> <td>Within 3</td> </tr> <tr> <td>3</td> <td>Maximum operating temperature⁺²₋₀</td> <td>30±3</td> </tr> <tr> <td>4</td> <td>Room temperature</td> <td>Within 3</td> </tr> </tbody> </table> Number of cycles : 10 cycles (LHL□□□) : 5 cycles (FBA, FBR) Recovery : 4 to 24hrs of recovery under the standard condition after the removal from the test chamber. (LHL□□□) : 3hrs of recovery under the standard condition after the removal from the test chamber. (FBA, FBR) FL : According to JIS C0025 Conditions for 1 cycle <table border="1"> <thead> <tr> <th>Step</th> <th>Temperature (°C)</th> <th>Duration (min)</th> </tr> </thead> <tbody> <tr> <td>1</td> <td>-25⁺⁰₋₃</td> <td>30±3</td> </tr> <tr> <td>2</td> <td>Room temperature</td> <td>Within 3</td> </tr> <tr> <td>3</td> <td>+85⁺²₋₀</td> <td>30±3</td> </tr> <tr> <td>4</td> <td>Room temperature</td> <td>Within 3</td> </tr> </tbody> </table> Number of cycles : 10 cycles Recovery : 1 to 2hrs of recovery under the standard condition after the removal from the test chamber.	Step	Temperature (°C)	Duration (min)	1	-25 ⁺⁰ ₋₃	30±3	2	Room temperature	Within 3	3	+85 ⁺² ₋₀	30±3	4	Room temperature	Within 3	Step	Temperature (°C)	Duration (min)	1	Minimum operating temperature ⁺⁰ ₋₃	30±3	2	Room temperature	Within 3	3	Maximum operating temperature ⁺² ₋₀	30±3	4	Room temperature	Within 3	Step	Temperature (°C)	Duration (min)	1	-25 ⁺⁰ ₋₃	30±3	2	Room temperature	Within 3	3	+85 ⁺² ₋₀	30±3	4	Room temperature	Within 3
Step	Temperature (°C)	Duration (min)																																																		
1	-25 ⁺⁰ ₋₃	30±3																																																		
2	Room temperature	Within 3																																																		
3	+85 ⁺² ₋₀	30±3																																																		
4	Room temperature	Within 3																																																		
Step	Temperature (°C)	Duration (min)																																																		
1	Minimum operating temperature ⁺⁰ ₋₃	30±3																																																		
2	Room temperature	Within 3																																																		
3	Maximum operating temperature ⁺² ₋₀	30±3																																																		
4	Room temperature	Within 3																																																		
Step	Temperature (°C)	Duration (min)																																																		
1	-25 ⁺⁰ ₋₃	30±3																																																		
2	Room temperature	Within 3																																																		
3	+85 ⁺² ₋₀	30±3																																																		
4	Room temperature	Within 3																																																		

Item	Specified Value						Test Method and Remarks
	FA02 Type	CAL45 Type	LHL□□□	FBA/FBR	FL05□ Type	FL06BT Type	
24.Damp heat	△L/L : Within±10% Q : 30min.	△L/L : Within±10%		Appearance : No abnormality Impedance change : Within±20%			FA・CA : Temperature : 40±2°C Humidity : 90~95%RH Duration : 1000 hrs Recovery : At least 1hr of recovery under the standard removal from test chamber, followed by the measurement within 2hrs. FB : Temperature : 60±2°C Humidity : 90~95%RH Duration : 1000 hrs Recovery : 1 to 2hrs of recovery under the standard condition after the removal from the test chamber.
25.Loading under damp heat	△L/L : Within±10% Q : 30min.	△L/L : Within±10%	Appearance : No abnormality Inductance change : Within±10% Q change : Within±30% (LHLP : only △L/L)	Refer to individual specification		Appearance : No abnormality Impedance change : Within±20%	FA・CA : Temperature : 40±2°C Humidity : 90~95%RH Duration : 1000 hrs Applied current : Rated current Recovery : At least 1hr of recovery under the standard removal from test chamber, followed by the measurement within 2hrs. LHL□□□ : Temperature : 40±2°C Humidity : 90~95%RH Duration : 1000±24 hrs Applied current : Rated current Recovery : 1 to 2hrs of recovery under the standard condition after the removal from the test chamber. FL : Temperature : 60±3°C Humidity : 90~95%RH Duration : 500 (+12, -0)hrs Applied current : Rated current Recovery : 1 to 2hrs of recovery under the standard condition after the removal from the test chamber.
26.Loading at high temperature	△L/L : Within±10% Q : 30min.	△L/L : Within±10%					FA・CA : Temperature : 85±2°C Duration : 1000 hrs Applied current : Rated current Recovery : At least 1hr of recovery under the standard removal from test chamber, followed by the measurement within 2hrs.

Item	Specified Value						Test Method and Remarks
	FA02 Type	CAL45 Type	LHL□□□	FBA/FBR	FL05□ Type	FL06BT Type	
27.Low temperature life test	△L/L : Within±10% Q : 30min.	△L/L : Within±10%	Appearance : No abnormality Inductance change : Within±10% Q change : Within±30% (LHLP : only △L/L)		Refer to individual specification	Appearance : No abnormality Impedance change : Within±20%	FA・CA : Temperature : -25±2°C Duration : 1000 hrs Recovery : At least 1hr of recovery under the standard removal from test chamber, followed by the measurement within 2hrs. LHL□□□ : Temperature : -40±3°C Duration : 1000±24 hrs Recovery : 1 to 2hrs of recovery under the standard condition after the removal from the test cfamber. FL : Temperature : -40±3°C Duration : 500 (+12, -0) hrs Recovery : 1 to 2hrs of recovery under the standard condition after the removal from the test cfamber.
28.High temperature life test			Appearance : No abnormality Inductance change : Within±10% Q change : Within±30%		Refer to individual specification	Appearance : No abnormality Impedance change : Within±20%	LHL□□□ : Temperature : 105±3°C Duration : 1000±24 hrs Recovery : 1 to 2hrs of recovery under the standard condition after the removal from the test cfamber. FL : Temperature : 85±3°C Duration : 500 (+12, -0) hrs Recovery : 1 to 2hrs of recovery under the standard condition after the removal from the test cfamber.

PRECAUTIONS

FA Type, CAL Type, LH Type, FB Type, FL Type

Stages	Precautions	Technical considerations
1.Circuit Design	<p>Operating environment,</p> <p>1.The products described in this specification are intended for use in general electronic equipment,(office supply equipment, telecommunications systems, measuring equipment, and household equipment). They are not intended for use in mission-critical equipment or systems requiring special quality and high reliability (traffic systems, safety equipment, aerospace systems, nuclear control systems and medical equipment including life-support systems,) where product failure might result in loss of life, injury or damage. For such uses, contact TAIYO YUDEN Sales Department in advance.</p>	
2.PCB Design	<p>Design</p> <p>1.Please design insertion pitches of a base in the pitches that fitted a terminal interval.</p>	<p>1.When Inductors are mounted onto a PC board, hole dimensions on the board should match the lead pitch of the component, if not, it will cause breakage of the terminals or cracking of terminal roots covered with resin as excess stress travels through the terminal legs.</p>
3.Considerations for automatic placement	<p>Adjustment of mounting machine</p> <p>1.Excessive impact load should not be imposed on the products when mounting onto the PC boards.</p> <p>2.Mounting and soldering conditions should be checked beforehand.</p>	<p>1. When installing products, care should be taken not to apply distortion stress as it may deform the products.</p>
4.Soldering	<p>Wave soldering</p> <p>1.Please refer to the specifications in the catalog for a wave soldering.</p> <p>2.Do not immerse the entire Inductors in the flux during the soldering operation.</p> <p>Lead free soldering</p> <p>1.When using products with lead free soldering, we request to use them after confirming of adhesion, temperature of resistance to soldering heat, soldering etc sufficiently.</p> <p>Recommended conditions for using a soldering iron:</p> <p>Put the soldering iron on the land-pattern.</p> <p>Soldering iron's temperature - Below 350 °C</p> <p>Duration - 3 seconds or less</p> <p>The soldering iron should not directly touch the inductor.</p> <p>◆Reflow soldering</p> <p>1.As for reflow soldering, please contact our sales staff.</p>	<p>1.If products are used beyond the range of the recommended conditions, heat stresses may deform the products, and consequently degrade the reliability of the products.</p>
5.Cleaning	<p>Cleaning conditions</p> <p>1.CP Type, LA type, CAL type, LH type</p> <p>Please do not do cleaning by a supersonic wave.</p>	<p>CP Type, LA type, CAL type, LH type</p> <p>1.If washing by supersonic waves, supersonic waves may deform products.</p>
6.Handling	<p>Handling</p> <p>1.Keep the inductors away from all magnets and magnetic objects.</p> <p>Mechanical considerations</p> <p>1.Please do not give the inductors any excessive mechanical shocks.</p> <p>2.LH type</p> <p>If inductors are dropped onto the floor or a hard surface they should not be used.</p> <p>Packing</p> <p>1.Please do not give the inductors any excessive mechanical shocks.</p> <p>In loading, please pay attention to handling indication mentioned in a packing box (a loading direction / number of maximum loading / fragile item).</p>	<p>1.There is a case that a characteristic varies with magnetic influence.</p> <p>1.There is a case to be damaged by a mechanical shock.</p> <p>2.LH type</p> <p>There is a case to be broken by a fall.</p> <p>1.There is a case that a lead route turns at by a fall or an excessive shock.</p>
7.Storage conditions	<p>Storage</p> <p>1.To maintain the solderability of terminal electrodes and to keep the packing material in good condition, temperature and humidity in the storage area should be controlled..</p> <p>•Recommended conditions</p> <p>Ambient temperature 0~40°C</p> <p>Humidity Below 70 % RH</p> <p>The ambient temperature must be kept below 30°C. Even under ideal storage conditions, solderability of products electrodes may decrease as time passes. For this reason, inductors should be used within one year from the time of delivery.</p> <p>In case of storage over 6 months, solderability shall be checked before actual usage.</p>	<p>1. Under a high temperature and humidity environment, problems such as reduced solderability caused by oxidation of terminal electrodes and deterioration of taping/packaging materials may take place.</p>